



omnisens

PARIS



Hotel line

TAKE TIME
to indulge YOURSELF...

omnisens

PARIS



« True luxury is taking time to live,
rediscover nature's bounty,
listen to your desires
and live a healthy life »

« El auténtico lujo consiste en dedicar
tiempo a vivir, a redescubrir la generosidad
de la naturaleza, a escuchar los deseos de
uno mismo y a llevar una vida saludable »

JOËLLE GUILLEMOT
FOUNDER OMNISENS

At the start of the company: a philanthropist deeply passionate about nature. Joëlle Guillemot is a psychologist and executive coach; she started Omnisens in 2008 as a response to the need to conjugate our desires for well-being and personal equilibrium with the hectic lifestyles that we lead today.

She became deeply convinced that true beauty can only come through the expression of emotions and consequently created a brand-name around the idea of well-being.

Detrás de la empresa está una filántropa profundamente apasionada por la naturaleza. Joëlle Guillemot es psicóloga y coach de ejecutivos. En 2008, crea Omnisens como solución a la necesidad de conjugar los deseos de bienestar y equilibrio de cada persona con los frenéticos estilos de vida que se llevan hoy en día. Estaba verdaderamente convencida de que la auténtica belleza solo podía manifestarse a través de la expresión de las emociones y, en consecuencia, creó un nombre de marca en torno al concepto de bienestar.

THE AWAKENING OF THE SENSES

Each product and each treatment bet on sensoriality to stimulate emotion and well-being.

BACK TO NATURE

Our formulas are composed of an average of 91% ingredients of natural origin.

THE CONTEMPORARY SPA SPIRIT

Natural active ingredients highlighted by clean lines, to refocus on the essentials.

EL DESPERTAR DE LOS SENTIDOS

Cada uno de los productos y cuidados apuesta por la sensorialidad como estimulante de las emociones y el bienestar.

VUELTA A LA NATURALEZA

Nuestras fórmulas, de media, se componen de un 91 % de ingredientes de origen natural.

EL ESPÍRITU SPA CONTEMPORÁNEO

La simplicidad de las líneas realza los ingredientes activos naturales, poniendo lo esencial en el foco.





omnisens

PARIS



The deep vitality of FRAÎCHEUR TONIQUE® is reflected in the Omnisens amenities.

The line is enriched with White tea extracts and the formulas, with their subtle notes of Green Tea and Bergamot, are vegan and contain up to 98% of natural origin ingredients.

La profunda vitalidad de FRAÎCHEUR TONIQUE® se refleja en los productos de cortesía Omnisens. Esta línea está enriquecida con extractos de té blanco, y las fórmulas, con notas sutiles de té verde y bergamota, son veganas y contienen un 98 % de ingredientes de origen natural.

CARE
ABOUT
eARTH

Omnisens amenity range is fully in line with Groupe GM's CARE ABOUT EARTH program and contributes to the corporate effort to lower its impact on the environment. Visit us on www.care-about-earth.com

La gama de productos de cortesía Omnisens sigue la línea del programa CARE ABOUT EARTH de Groupe GM y contribuye al esfuerzo corporativo de reducir su impacto en el medioambiente. Visítenos en www.care-about-earth.com

Tubes Tubos

30 ml - 1.01 fl.oz

CARE ABOUT EARTH



90% PLANT-BASED TUBE



RECYCLED PLASTIC CAP

Bath Shower Gel
Gel de ducha

Shampoo
Champú

Conditioner
Acondicionador

Body Lotion
Loción corporal

Hair & Body Gel
Gel para cuerpo y cabello



Soaps Jabones

CARE ABOUT EARTH



Soap
Jabón

20 g - 0.70 oz

Exfoliating
Massage Soap
Jabón exfoliante para masajes

30 g - 1.05 oz



Solid Sólido

15 g - 0.52oz

Hair & Body Wash
Gel para cuerpo y cabello



CARE ABOUT EARTH



WATER VOLUME REDUCED BY 9 DURING MANUFACTURING

100% PLASTIC FREE



Bottles Botellas

50 ml - 1.69 fl.oz

CARE ABOUT EARTH



100% PLANT-BASED BOTTLE

Bath Shower Gel
Gel de ducha

Shampoo
Champú

Conditioner
Acondicionador

Body Lotion
Loción corporal



Hand cream Crema de manos

30 ml - 1 fl.oz

CARE ABOUT EARTH



90% PLANT-BASED TUBE



RECYCLED PLASTIC CAP



Dry oil Aceite seco

20 ml - 0.67 fl.oz



Bath salts Sales de baño

30 g - 1.05 oz



Ecopump

300 ml - 10.14 fl.oz

CARE
ABOUT
EARTH



100%
PLANT-BASED
BOTTLE



BIO-RESIN
PUMP

Liquid Soap
Jabón líquido

Hair & Body Gel
Gel para cuerpo y cabello

omnisens
PARIS



THÉ
TONIQUE®

Savon Liquide
- Mains -

Liquid Soap
- Hands -

PRENEZ soin
d'être BIEN...
TAKE time
to indulge YOURSELF...

300 ml 10.14 fl.oz.



Wall brackets

Soportes de pared

Stainless steel or ABS recyclable
black or white plastic.
Can be fixed with 2 screws
or double-sided tape.

*Acero inoxidable o plástico reciclable ABS
en blanco o negro.
Se puede fijar con 2 tornillos o con cinta
adhesiva de doble cara.*

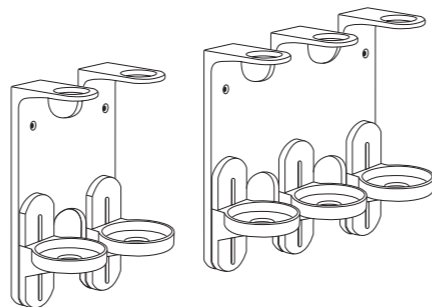

omnisens
PARIS



THÉ
TONIQUE®

Gel Cheveux & Corps
- Cheveux & Corps -

Hair & Body Gel
- Hair & Body -

PRENEZ soin
d'être BIEN...
TAKE time
to indulge YOURSELF...

300 ml 10.14 fl.oz.

Ecofill

400 ml - 13.53 fl.oz



THE CLEAN, SAFE, FAST & EASY
REFILLABLE DISPENSER

CARE
ABOUT
EARTH

REUSABLE
SAFE REFILLABLE
ECO-DESIGNED
SUSTAINABLE



100%
POST-INDUSTRIAL
RECYCLED
PLASTIC BOTTLE



8g
RECYCLABLE
POUCH

COSMETIC
100%
TRACEABLE



Refill pouch Bolsa recargable

Liquid Soap
Jabón líquido

Hair & Body Gel
Gel para cuerpo y cabello

Wall brackets Soportes de pared

Stainless steel
or ABS recyclable
black or white plastic.

Can be fixed
with 2 screws
or double-sided tape.

Acero inoxidable o plástico
reciclable ABS en blanco
o negro.

Se puede fijar con 2 tornillos
o con cinta adhesiva
de doble cara.



EL DISPENSADOR LIMPIO, SEGURO,
RÁPIDO Y FÁCIL DE RELLENAR

RÁPIDO Y FÁCIL

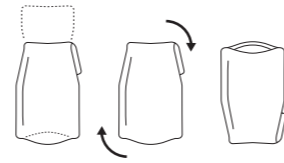

FOLD & TURN / DOBLAR Y DAR
LA VUELTA

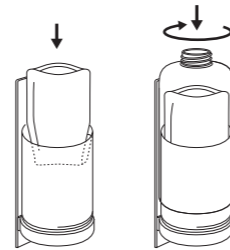

INSERT / INTRODUCIR

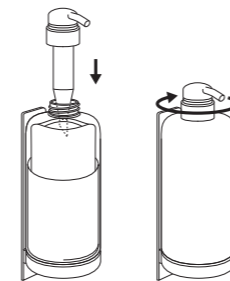

PIERCE / PERFORAR



The EU Ecolabel is the
official European eco-label
that promotes sustainable
product design.

El EU Ecolabel es el sello
ecológico europeo oficial
que promueve el diseño
de productos sostenibles.



The Nordic Swan Ecolabel
is an environmental
certification of the Nordic
countries that encourages
sustainable products
conception.

El Nordic Swan Ecolabel
es un certificado medio-
ambiental de los países
nórdicos que incentiva
la concepción de productos
sostenibles.

Ecosource

375 ml - 12.68 fl.oz



Refill bag Recharge

CARE
ABOUT
EARTH

PRESERVATIVE
FREE
EXCLUSIVE
AIRLESS
TECHNOLOGY

Hair & Body Gel
Gel para cuerpo y cabello

Liquid Soap
Jabón líquido

Conditioner*
Acondicionador*

* Not Ecolabel certified
* Sin certificado Ecolabel



Also available
in double
dispenser

También
disponible
en doble
dispensador

www.omnisens.fr

